

Atrax Overhead Track Scales

Precision carcass weighing on the rail,
engineered by the world leader in industrial
weighing systems



- Hygienic, trade-approved weighing for meat rail systems
- Fast, simple installation into existing meat hook rails
- Built for harsh washdown, cold rooms and hot production areas
- Backed by Atrax engineering, electronics and global support

ATRAX



Accuracy, hygiene and uptime built into every rail

When every carcass and every kilo counts, you need weighing that's fast, hygienic and absolutely dependable.

Atrax Overhead Track Scales slot straight into your existing overhead meat hook rails, delivering accurate on-rail weighing without slowing production or compromising hygiene.

Drawing on Atrax's global experience in high-duty industrial weighing, the system combines robust mechanical design, a stainless steel live rail section and proven Atrax electronics to keep your plant compliant and your line moving, shift after shift.

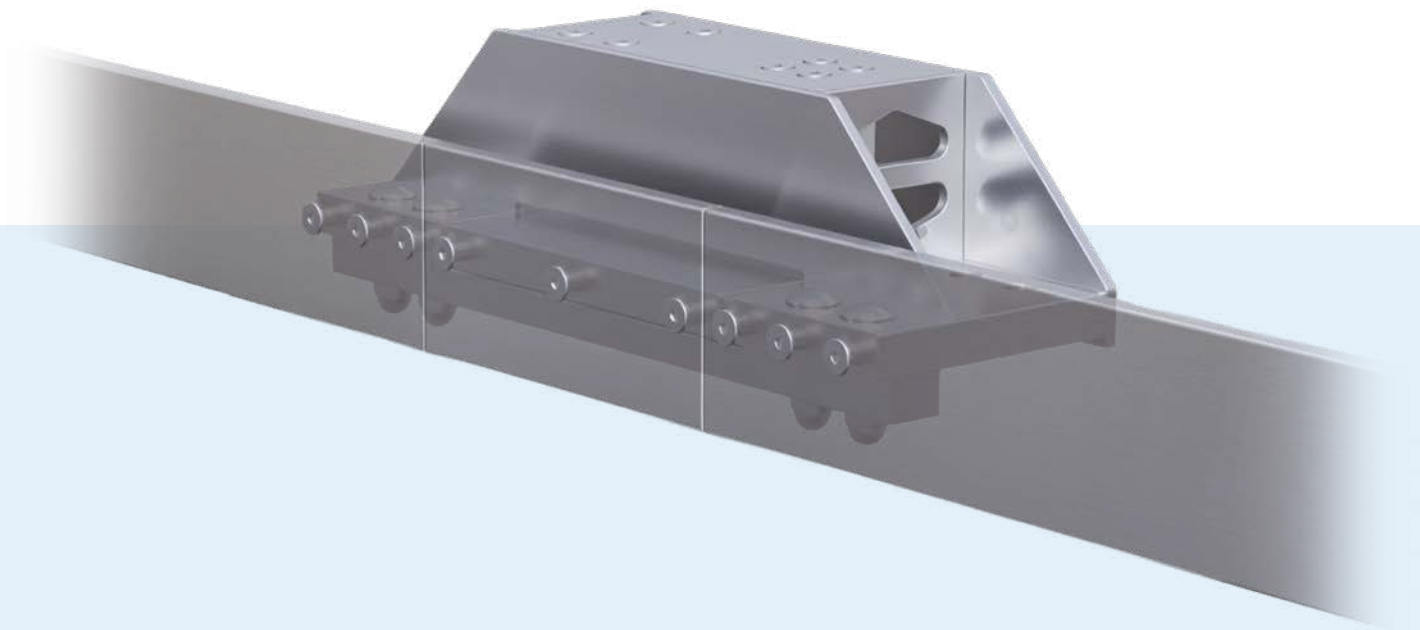

Key benefits at a glance

- **Protect yield and margin** – Accurate carcass weights reduce giveaway and shrinkage, supporting precise yield calculations and fair producer payments.
- **Maintain hygiene and compliance** – Overhead, above-floor weighing keeps product off platforms and out of pits, making cleaning easier and helping you meet strict food safety standards.
- **Keep throughput high** – Fast, stable weighing on the rail keeps your line moving; no need to divert carcasses to separate floor scales or create bottlenecks.
- **Minimise downtime and cost of ownership** – Durable, corrosion-resistant materials, sealed load cells and a low-maintenance design withstand repeated washdowns and heavy use with less maintenance over the life of the system.
- **Better data, better decisions** – When combined with Atrax indicators and control systems, carcass weights feed directly into production reporting, yield analysis and quality systems, giving supervisors real-time information to optimise operations.
- **Rely on proven Atrax engineering** – Atrax systems are trusted in some of the world's toughest weighing environments, from busy airports to heavy-duty logistics operations.

Engineered for demanding meat plants

Atrax Overhead Track Scales are purpose-built for meat processing environments, where equipment must handle constant loading, aggressive washdown and high throughput without drifting out of spec.

Core features

- **Stainless steel live rail section** – Replaces a short section of your existing meat hook rail, maintaining smooth trolley transition and safe operation.
- **Sealed, washdown-rated load cell** – Designed for wet, corrosive and washdown environments typical of meat processing plants.
- **Compact installation footprint** – Short live-rail section fits into existing straight rail, minimising structural changes and making installation fast and simple.
- **Trade-approved weighing** – Configured for legal-for-trade use when paired with an approved indicator, helping ensure accurate payment to suppliers and fair billing to customers.
- **Flexible indicator compatibility** – Works with Atrax digital weight indicators for simple standalone operation or full integration with plant-wide systems and software.
- **Low-maintenance assembly** – Minimal moving parts and robust construction help reduce service requirements and unplanned downtime.

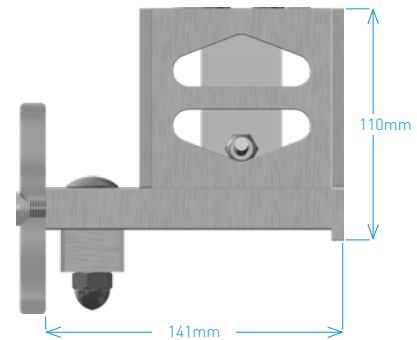
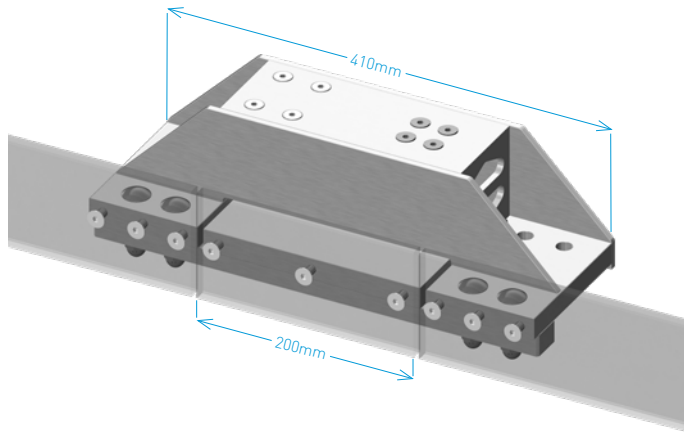

Part of a complete Atrax weighing solution

Atrax Overhead Track Scales can be supplied as standalone units or as part of a fully integrated weighing and data system.

Configuration options

- Multiple capacity and rail length options to suit different carcass sizes and line layouts
- Choice of rail profiles to match existing track systems
- Indicator options – from simple local displays to fully programmable networked indicators
- Mounting and hardware kits to streamline installation and ensure alignment

Integration options

- Connect to Atrax digital weight indicators for clear, bright weight display and easy operator use
- Link to line controls, PLCs and plant management systems for automated data capture and reporting
- Integrate with weighing software and ERP systems (via serial, Ethernet or fieldbus interfaces, depending on system design)
- Connectivity to PC or other equipment via various communications protocols. Please ask.

MODEL 8011	8011-060	8011-150	8011-300	8011-600
Capacity (kg)	60	150	300	600
Readability (g)	20	50	100	200
Load cell type	Single point s/steel or Alloy options			
Construction/finish	Stainless steel 304			
IP rating	IP 65 or IP 67 / 69K			
Compatible indicators	Will calibrate to most modern analogue indicators			

Specifications may vary by model and installation. Custom configurations are available. Talk to us about your exact rail and capacity requirements, we can custom design and build to your specification.

Designed for where real work happens

Atrax Overhead Track Scales are suitable for:

- **Slaughter floors and hot rooms** – Weigh carcasses at receiving or as part of the primary processing line.
- **Chillers and cold stores** – Verify weights after chilling for shrink analysis and inventory accuracy.
- **Boning rooms and cutting areas** – Capture primal and sub-primal weights to support yield, costings, and traceability.
- **Further processing and value-add** – Integrate weighing into overhead conveying systems for sausages, smallgoods or other hanging products.
- **Other suitable environments** – Where overhead rail systems are used for heavy or messy products requiring washdown – such as poultry, seafood and some industrial or produce processing lines – Atrax Overhead Track Scales provide the same combination of hygiene and durability.

Atrax. Weighing expertise you can build on.

Atrax is a world leader in the design, manufacture, integration and support of industrial weighing, measurement and control systems, used at over 800 sites in more than 165 countries and territories.

Our engineering, electronics and systems expertise have been proven in some of the world's most demanding environments. With our Overhead Track Scales, that same reliability and accuracy is now available for your meat processing operations.

Talk to Atrax about your rail line.

- ☎ **0800 4 ATRAX** | 0800 428 729 | +64 9 634 5337
- ✉ servicenz@atraxgroup.com
- 💻 atraxgroup.com | weightrax.com
- 🌐 **Atrax offices:** New Zealand | Australia | Malaysia | China | USA

