

VIEW ON REAR
SCALE: 1:2.5

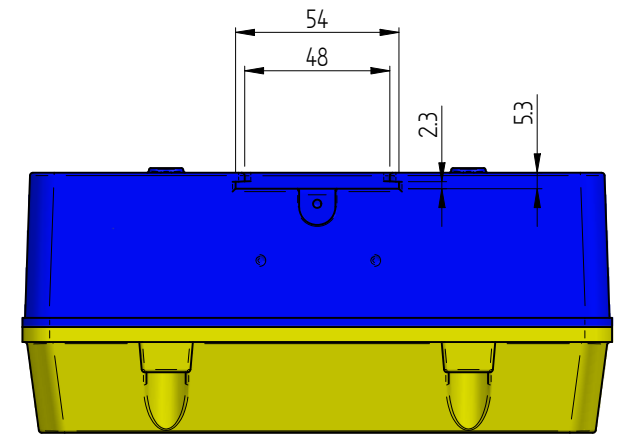

VIEW ON SLOT
SCALE: 1:2.5

3RD ANGLE PROJECTION

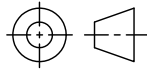

UNITS: mm

A3

ATRAX

390A Church St, Penrose
Auckland, New Zealand
PO Box 11 087 Ellerslie, Auckland
Ph 64-9-634 5337 Fax 64-9-634 5339

FINISH: -

BY	ECN	ISSUE	DATE	NGS	BY	ECN	ISSUE	DATE	SCALE	DRG.	APP.	DATE
				-					N.T.S	N.SMITH	K.M.	31/5/11
				P1				6/7/13				31/5/11

MATERIAL AS NOTED

PRODUCT
MULTI-USE ENCLOSURE BOX

DRAWING TITLE
GENERAL ASSEMBLY

PART NO.

E-BOX-145-195

SHEET 1 OF 2

DRG NO.

AT020686A

ISSUE

P1

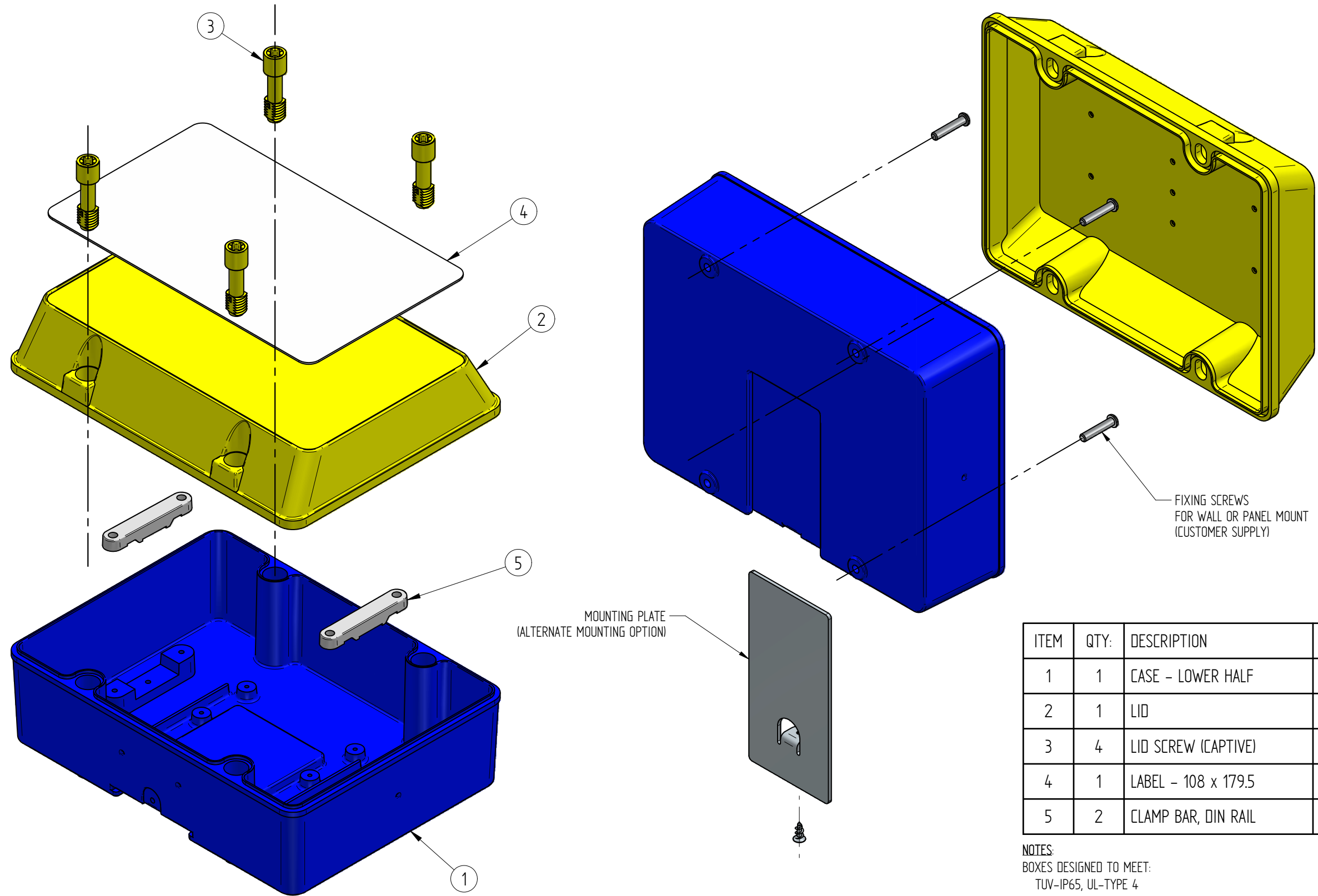

FIXING SCREWS FOR WALL OR PANEL MOUNT (CUSTOMER SUPPLY)

MOUNTING PLATE (ALTERNATE MOUNTING OPTION)

ITEM	QTY:	DESCRIPTION	MATL:
1	1	CASE - LOWER HALF	ABS Plastic, high impact
2	1	LID	ABS Plastic, high impact
3	4	LID SCREW (CAPTIVE)	ABS Plastic, high impact
4	1	LABEL - 108 x 179.5	Polycarbonate
5	2	CLAMP BAR, DIN RAIL	ABS Plastic, high impact

NOTES:
BOXES DESIGNED TO MEET:
TUV-IP65, UL-TYPE 4
ROHS COMPLIANT

	ATRAX 390A Church St, Penrose Auckland, New Zealand PO Box 11 087 Ellerslie, Auckland Ph 64-9-634 5337 Fax 64-9-634 5339	FINISH: -								SCALE N.T.S		MATERIAL -		PART NO.														
		<table border="1"> <thead> <tr> <th>BY</th> <th>ECN</th> <th>ISSUE</th> <th>DATE</th> <th>BY</th> <th>ECN</th> <th>ISSUE</th> <th>DATE</th> </tr> </thead> <tbody> <tr> <td></td> <td></td> <td></td> <td></td> <td></td> <td></td> <td></td> <td></td> </tr> </tbody> </table>								BY	ECN	ISSUE	DATE	BY	ECN	ISSUE	DATE									DRG. N.SMITH	PRODUCT	
BY	ECN	ISSUE	DATE	BY	ECN	ISSUE	DATE																					
UNITS: mm	A3	NGS - P1 6/7/13								DATE 6/7/13	MULTI-USE ENCLOSURE BOX		SHEET 2 OF 2															
										APP.	DRAWING TITLE		DRG NO. AT020686A															
											GENERAL ASSEMBLY		ISSUE P1															