

VIEW ON REAR
SCALE: 12.5

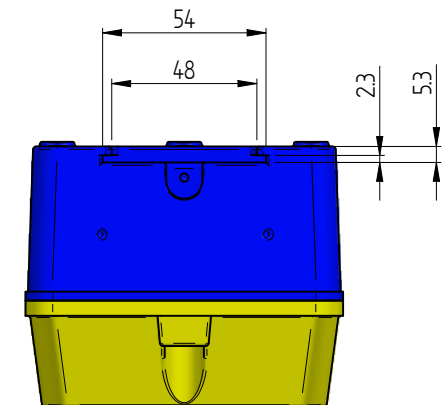

VIEW ON SLOT
SCALE: 12.5

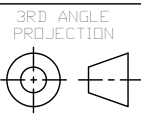

UNITS: mm

A3

ATRAX

390A Church St, Penrose
Auckland, New Zealand
PO Box 11 087 Ellerslie, Auckland
Ph 64-9-634 5337 Fax 64-9-634 5339

FINISH: -

BY	ECN	ISSUE	DATE	BY	ECN	ISSUE	DATE	DATE	31/5/11

SCALE
N.T.S

DRG. N.SMITH

DATE 31/5/11

APP. K.M.

DATE 31/5/11

MATERIAL AS NOTED

PRODUCT

MULTI-USE ENCLOSURE BOX

DRAWING TITLE

GENERAL ASSEMBLY

PART NO.

E-BOX-105-105

SHEET 1 OF 2

DRG NO.

AT020686A

ISSUE

P1

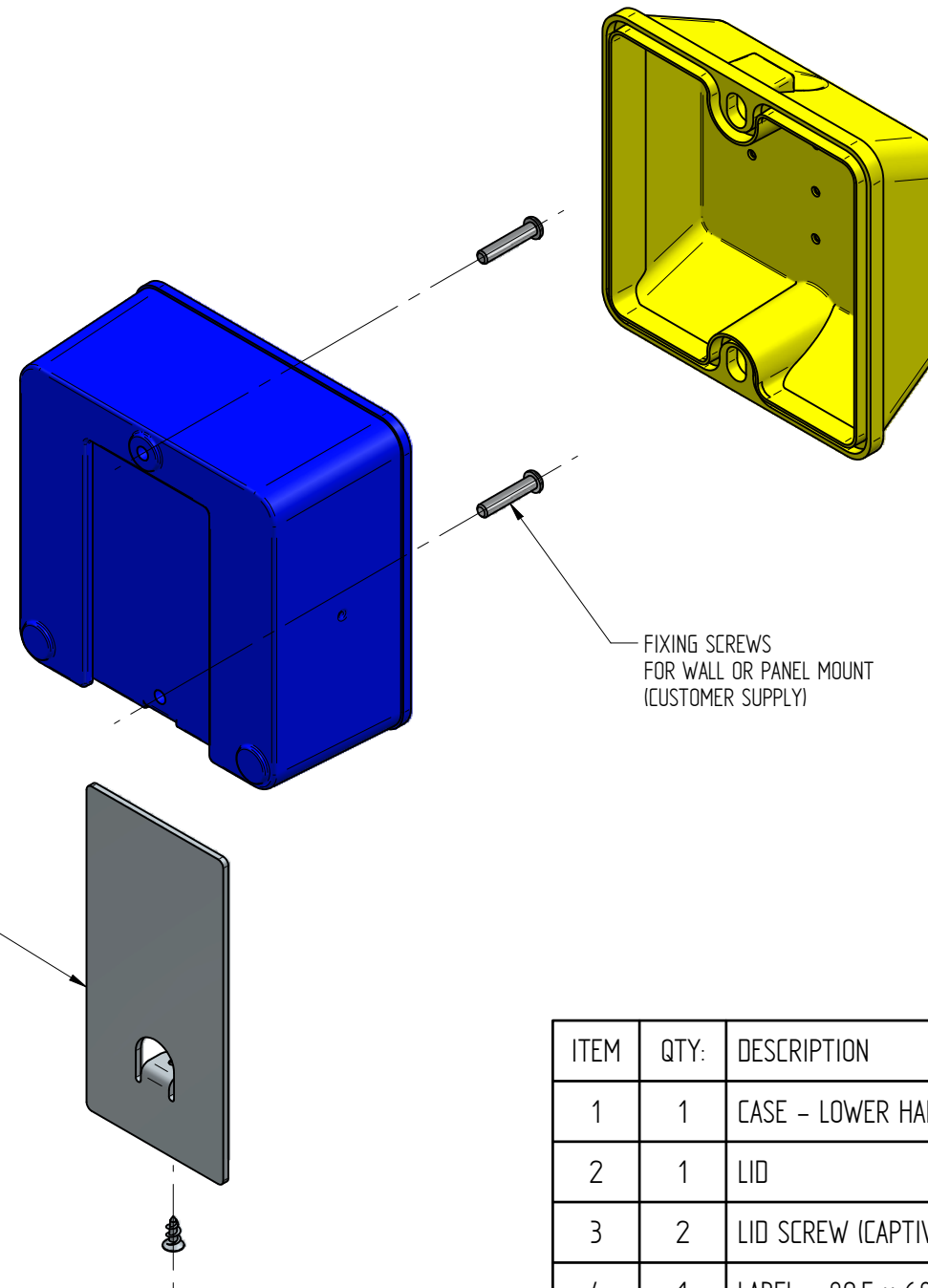
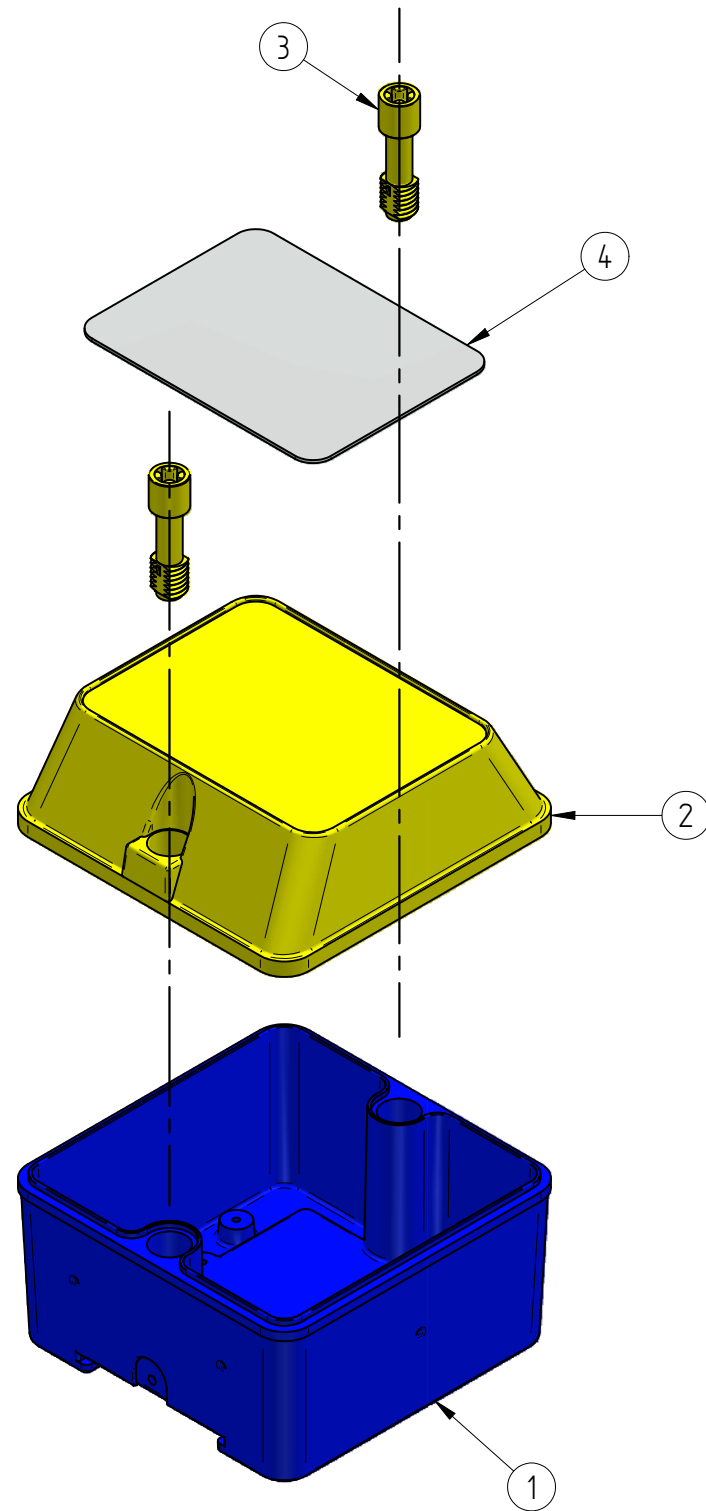

MOUNTING PLATE
(ALTERNATE MOUNTING OPTION)

ITEM	QTY:	DESCRIPTION	MATL:
1	1	CASE - LOWER HALF	ABS Plastic, high impact
2	1	LID	ABS Plastic, high impact
3	2	LID SCREW (CAPTIVE)	ABS Plastic, high impact
4	1	LABEL - 89.5 x 68	Polycarbonate

NOTES:
BOXES DESIGNED TO MEET:
TUV-IP65, UL-TYPE 4
ROHS COMPLIANT

		FINISH: -								MATERIAL		PART NO.	
										SCALE N.T.S		E-BOX-105-105	
UNITS: mm	390A Church St, Penrose Auckland, New Zealand									PRODUCT		SHEET 2 OF 2	
A3	PO Box 11 087 Ellerslie, Auckland									MULTI-USE ENCLOSURE BOX		DRG NO.	
	Ph 64-9-634 5337 Fax 64-9-634 5339	NGS - P1 6/7/13									DRAWING TITLE		ISSUE
		BY	ECN	ISSUE	DATE	BY	ECN	ISSUE	DATE	GENERAL ASSEMBLY		AT020686A P1	