

Cabin Baggage Test Unit

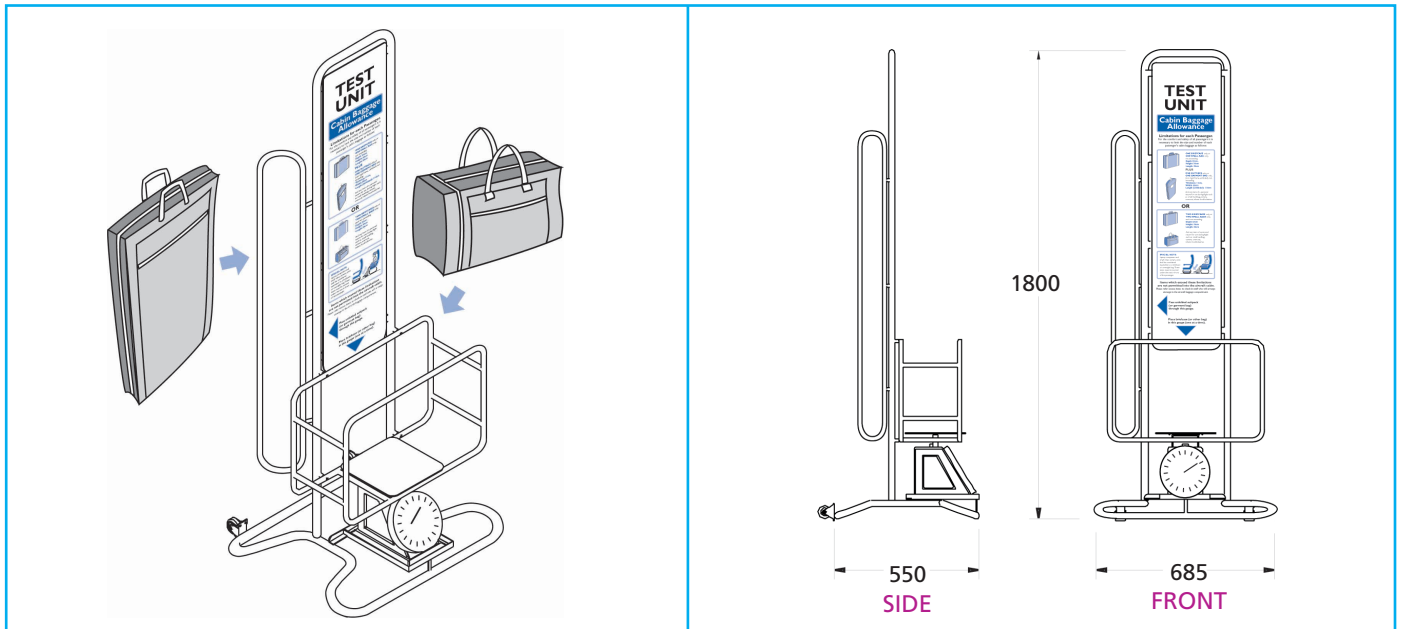

The **Cabin Baggage Test Unit** is a simple and attractive unit to test the size and weight (measurement only available if optional scales included) of cabin hand luggage allowed on domestic or international flights. The white powdercoated and chrome tubular steel unit is fitted with a panel to give details of all size and quantity restrictions for hand luggage and suit packs allowed onto the aircraft. Ideal for use in luggage shops, travel agents, airport lounges, ticket allocation and check in areas.

BAGGAGE GAUGE

- Low profile design
- To test the size of carry-on bags and briefcases.
- For bag sizes up to 23cm depth x 36cm height x 56cm long (Standard gauge).
- Constructed from tubular steel with a polished chrome finish.

SIDE GAUGE

- Low profile design
- To test the size and thickness of suit packs.
- For pack sizes up to 11cm thick x 60cm wide x 114cm length (unfolded).
- Constructed in tubular steel with a white powdercoat finish.

GRAPHIC PANEL

- Low profile design
- Our standard panel shows a full explanation of allowances and limitations.
- Panel is constructed from High Impact Polystyrene with screen printed graphics.
- If optional scales are utilised additional weight allowance text will be applied ie. Weight limit per bag - 7kg (15lb).

WHEELS

- 50mm (2") castors welded to the frame for easy relocation and movability.

SCALES (OPTIONAL)

- To test weight of carry-on baggage.
- Scales up to 20kg capacity.
- Chrome and stainless steel finish.

Atrax Group NZ Limited.

111 Mays Road, Penrose, Auckland, New Zealand. Telephone 64 9 634 5337,
Facsimile: 64 9 634 5339, E-mail: atrax@atraxgroup.com Internet: www.atraxgroup.com

R0700

ATRAX