

SSC Series

Compression Load Cell, from 0.5 tonne to 500 tonne

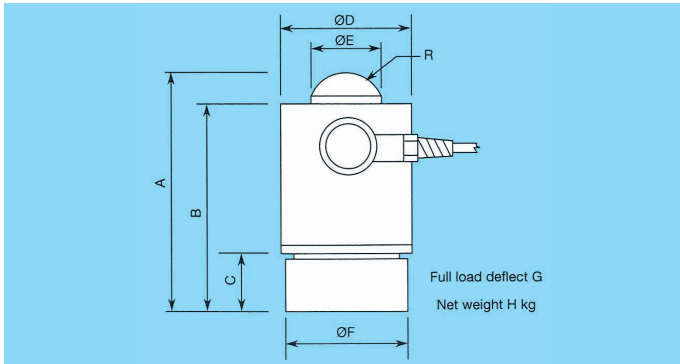

Capacity Model

0.5t	SSC 0.5
1t	SSC 1
2t	SSC 2
5t	SSC 5
10t	SSC 10
20t	SSC 20
50t	SSC 50
100t	SSC 100
200t	SSC 200
500t	SSC 500

Our automated stainless steel welding technique used in construction of the SSC ensures best environmental protection and strength to provide years of trouble free service.

SPECIFICATION

SSC Series

Nominal capacity	0.5t to 500 tonne
Nominal output at capacity	1mV/V±0.1%
Factory calibration mode	compression
Linearity error	0.05%
Repeatability	0.02%
Zero return, creep (30 mins)	0.03%
Temp. effect span/10 deg. C	0.025%
Temp. effect zero/10 deg. C	0.025%
Insulation resistance - brg to gnd	>5000 M Ω
Insulation resistance - brg to gnd	>1000 M Ω
Compensated temp range	-10 to 50 deg C
Output resistance	705 Ω
Input resistance	820 Ω nominal
Service load	100% of capacity
Safe load	200% of capacity
Mechanical failure	>500% of capacity
Recommended excitation	5V to 20V ac/dc
Maximum excitation	25V dc
Environmental protection	IP67
Tilt, max transverse displacement	12mm

** All specifications are a maximum, as a % (±) of full load, unless otherwise stated.

Features.

- Stainless steel construction
- Simple installation for tanks, hoppers and silos
- Models for operation from -50 to 200°C
- Compatible with international models
- Standard mountings available for all capacities
- High safe overload capacity
- Special mountings designed to order
- Fully environmentally sealed to IP 67
- Output matched for multiple cell installations
- Individually calibrated, test certificate supplied

Atrax Group NZ Limited.

Telephone 64 9 634 5337, Facsimile: 64 9 634 5339,
E-mail: atrax@atraxgroup.com Internet: www.atraxgroup.com

DIMENSIONS

SSC	A	B	C	D	E	F	G	H	R
0.5t	138.5	120.5	33	76	38	70	0.1	3.2	15
1t	138.5	120.5	33	76	38	70	0.1	3.2	15
2t	138.5	120.5	33	76	38	70	0.1	3.2	15
5t	138.5	120.5	33	76	38	70	0.2	3.3	15
10t	138.5	120.5	33	76	38	70	0.2	3.3	15
20t	138.5	120.5	33	76	38	70	0.9	3.4	15
30t	138.5	120.5	33	90	38	70	1.2	3.6	35
50t	138.5	120.5	28	90	54	70	1.2	3.6	35
100t	200	168	53	114	76	105	1.6	15.8	50
200t	270	230	70	168	108	143	1.9	26.4	70
500t	440	370	90	219	165	200	2.3	63.6	115

Cabling

RED	+	EXCITATION
BLACK	-	EXCITATION
GREEN	+	SIGNAL
WHITE	-	SIGNAL
BROWN	+	SENSE
BLUE	-	SENSE

CABLE IS SIX CORE GREY, QUALITY PVC SHEATHED WITH SCREEN AND HAS A LENGTH AS FOLLOWS.

SSC 0.5t - 50t	10 METRES
SSC 100t - 200t	13 METRES
SSC 500t	15 METRES

